

Ø3.50mm 4 POLE PLUG

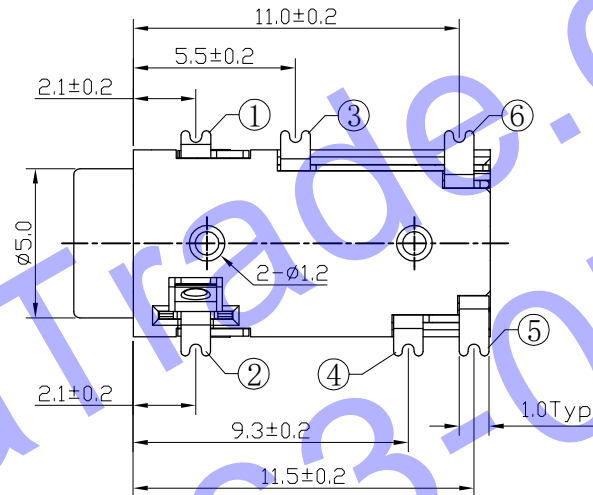

P. C. B LAYOUT  
TOP VIEW

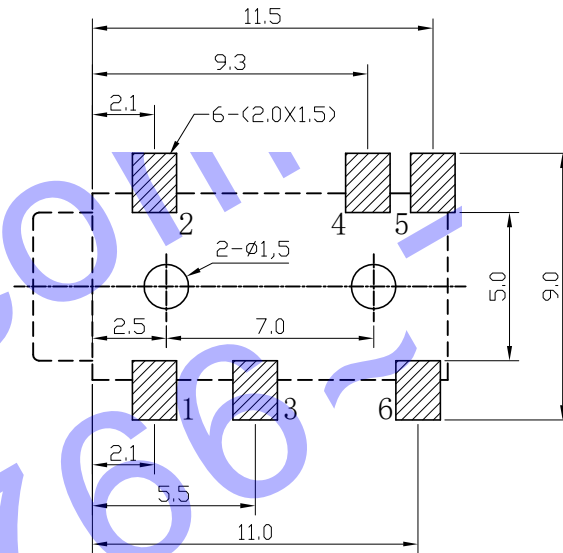

SCHEMATIC

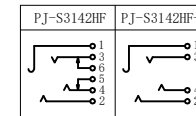

SPECIFICATION

1. Rating : DC 30V 0.5A;
2. Contact resistance:  $\leq 0.03 \Omega$ ;
3. Insulation resistance:  $\geq 100M \Omega$  (DC250V);
4. Withstand voltage: 500VAC ;
5. Insertion and extraction force: 3-30N;
6. life test: 5,000 cycles.

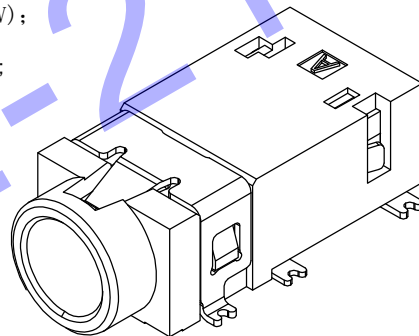

7	HOUSING	1	PA9T (HF)	
6	6# CONTACT FOOT	1	BRONZE	AU PLATING
5	5# CONTACT FOOT	1	BRONZE	AU PLATING
4	4# CONTACT FOOT	1	BRONZE	AU PLATING
3	3# CONTACT FOOT	1	BRONZE	AU PLATING
2	2# CONTACT FOOT	1	BRONZE	AU PLATING
1	1# CONTACT FOOT	1	BRONZE	AU PLATING
NO.	DESCRIPTION	QTY	MATERIAL	PLATING

UNIT:MM	TYPE:	MODEL NO:	PAPER NO: A4	PAGE 1 OF 1	
	PHONE JACK	PJ-S3142HF	TOLERANCE	ANGLES	SCALE
DESIGNER BY:			±0.15	±1.5°	4:1
CHECK BY:					VER
APPROVED BY:					0
			H D C 有限公司		